

AL SIMMONS

SOUNDS CRAZY

THE SCIENCE OF MUSIC



A MUSICAL EXPLORATION OF EVERYDAY THINGS

By Al Simmons
Illustrations - Shannon D. Schultz

Sounds Crazy

A MUSICAL EXPLORATION OF EVERYDAY THINGS

By Al Simmons

Even the most sophisticated of musical instruments have humble beginnings. Since saxophones and trombones don't grow on trees they must have evolved from stuff people found in their environment.

We can only imagine, but likely the first musicians accidentally twanged the string of their hunting bow, blew across the top of a piece of bamboo or between two blades of grass, or hit two sticks together. They were probably surprised by the sound they heard and experimented by trying to make the sound louder, prettier, lower or higher. Once they found sounds that they liked they shared their

discovery with friends who in turn shared their musical findings. The music sounded even more amazing when everyone played together. The first jam session!

Over many years of refinement these instruments gradually improved and became the modern instruments that we hear today.

We, too, can make music out of found items, even stuff that is headed for the landfill site. Our homemade instruments won't have the most sophisticated sounds, but their construction will have the essence of, and be played using the same principles as the finest, most expensive store-bought kind!

Some of the construction is tricky so be sure to ask a grown-up for help!

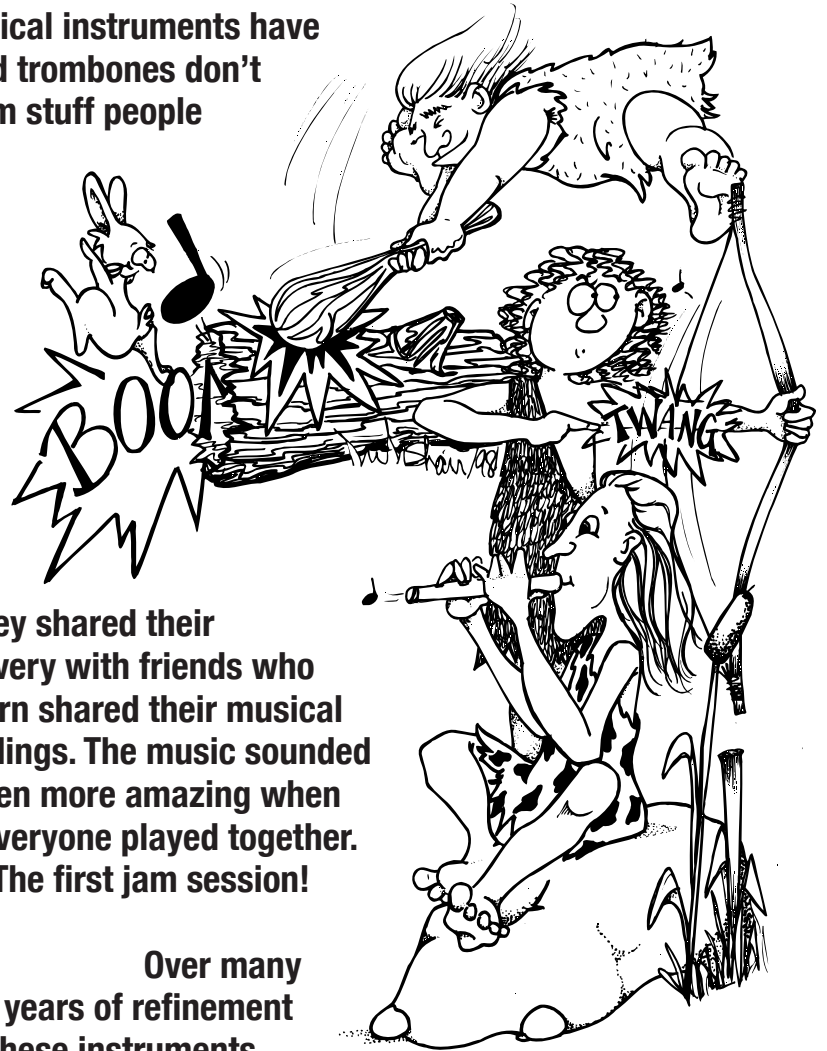

Word List



Tempo

Like the ticking of a clock or the dripping of a tap, tempo is the speed at which music is played. If all the musicians in a band played at a different tempo, all we would hear is noise.

Pitch

Pitch is the highness or lowness of a sound. Small instruments produce more rapid vibrations and have a higher pitch than larger instruments. The long thick strings of a bass fiddle vibrate slower and produce lower notes than the short strings of a violin.

Vibrations

A vibration is a sound wave moving back and forth from its highest to its lowest point. You can see what a sound wave looks like. Have two friends hold the cans at either end of a "Tin Can Telephone" - pull hard to keep the string tight. Create friction by squeezing a wet cloth on the string and dragging it from one end to the other (Like a Moose Call, page). See the string wobble? Those are the vibrations! Slow vibrations produce a low note and fast vibrations produce a higher note.

Hello Al! Can you come over for some soup? I want to put in an extension!

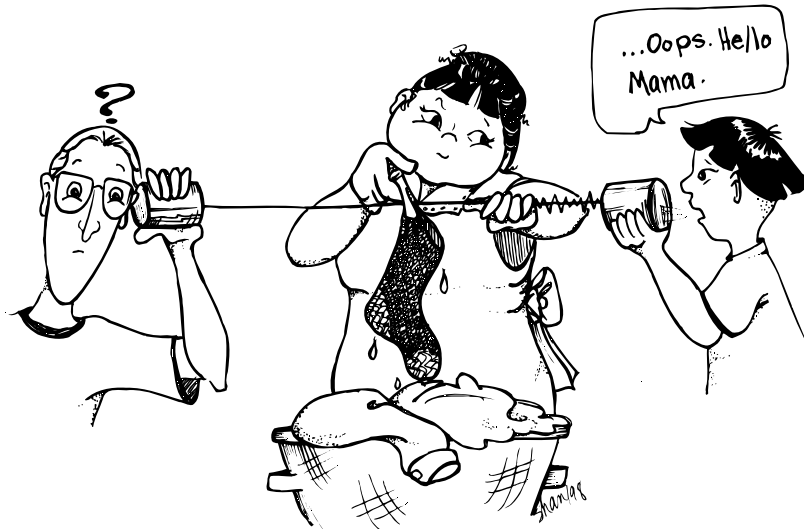

Strings

Violin, viola, cello, double bass, banjo and guitar all produce sound from a stretched string and are called Stringed Instruments.

Tin Can Violin (Moose Call)

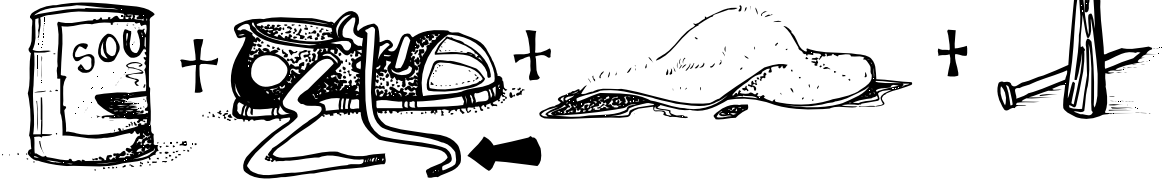

Get someone to help you punch a hole in the bottom of a tin can using a hammer and a nail. Thread a long cotton shoelace (or heavy cotton string) through the hole and tie a knot inside the can. Hold the shoelace firmly with a wet cloth and pull allowing the shoelace to slowly slip through the cloth. You will hear a loud honking sound. It sounds like a moose.

This moose call operates on the same principle as the most expensive Stradivarius.

A violin is made out of wood. My moose call's resonating chamber is a tin can. A violin has four strings, My moose call has one shoelace. A violin player puts rosin on her bow to create friction on the strings that sends vibrations up the strings to make music in the resonating chamber. I put water on my cloth for the same reason. When I squeeze and pull on the string, friction sends vibrations up the shoelace and into the tin can which amplifies the sound.

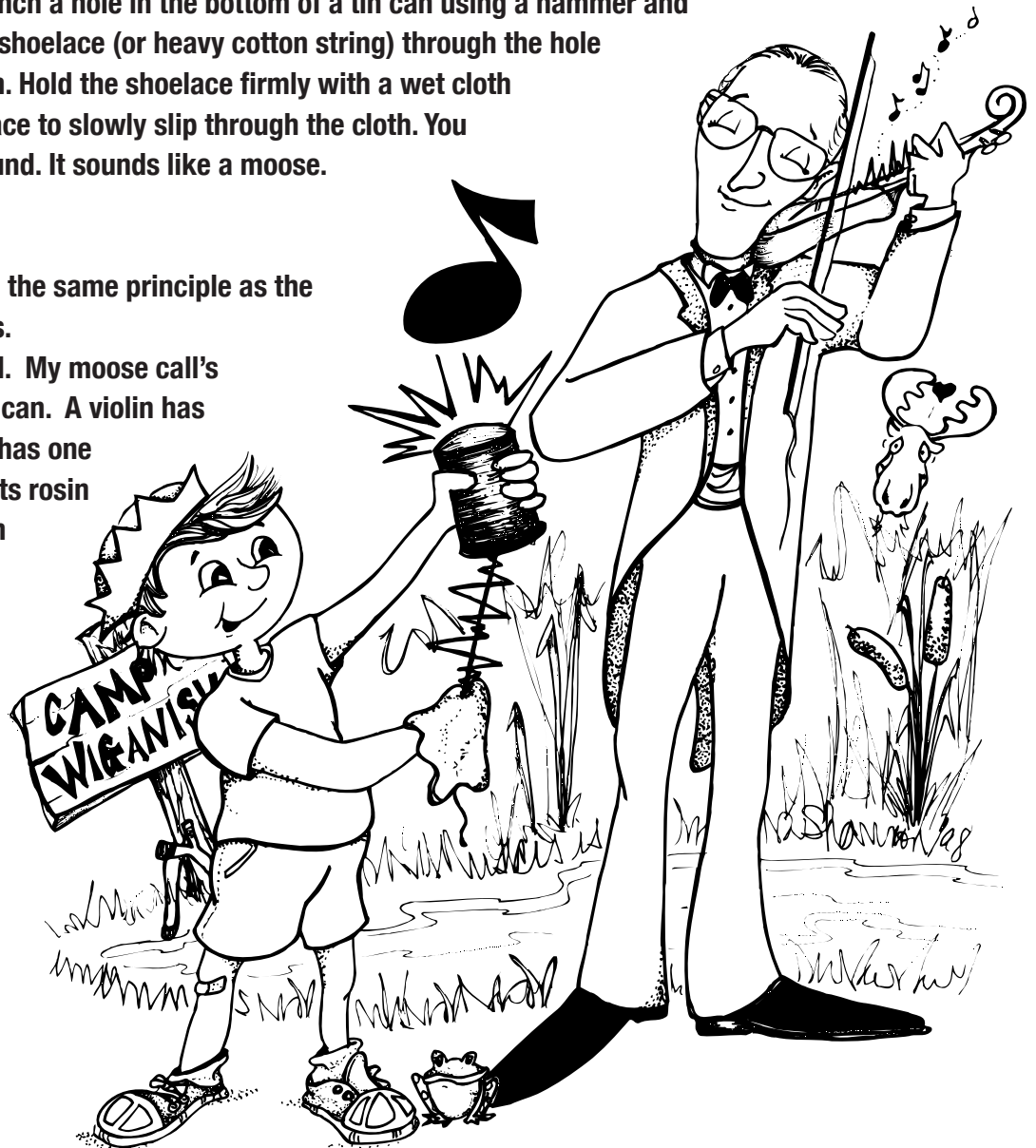

Tin Can Twanger

- 4 1" long 3/16" bolts
- 3 nuts
- 1 wing-nut
- 2 paint stir sticks
- 46 cm (18") fishing line or guitar string
- one empty can - 2.84L (100oz)



Find two paint stir sticks and a large empty juice can. A restaurant size tomato juice can works well, but a smaller one will be ok too. You will need to use a drill so get someone to help you with this project. Stand a stick against the inside wall of the can and drill two holes and fasten the stick in place using nuts and bolts. Please see the diagram.

Using another nut and a bolt, fasten the other paint stir stick to the top of the one you just mounted to the can. The two sticks should now look like a letter "T." Drill a small hole into the bottom of the can and stick a

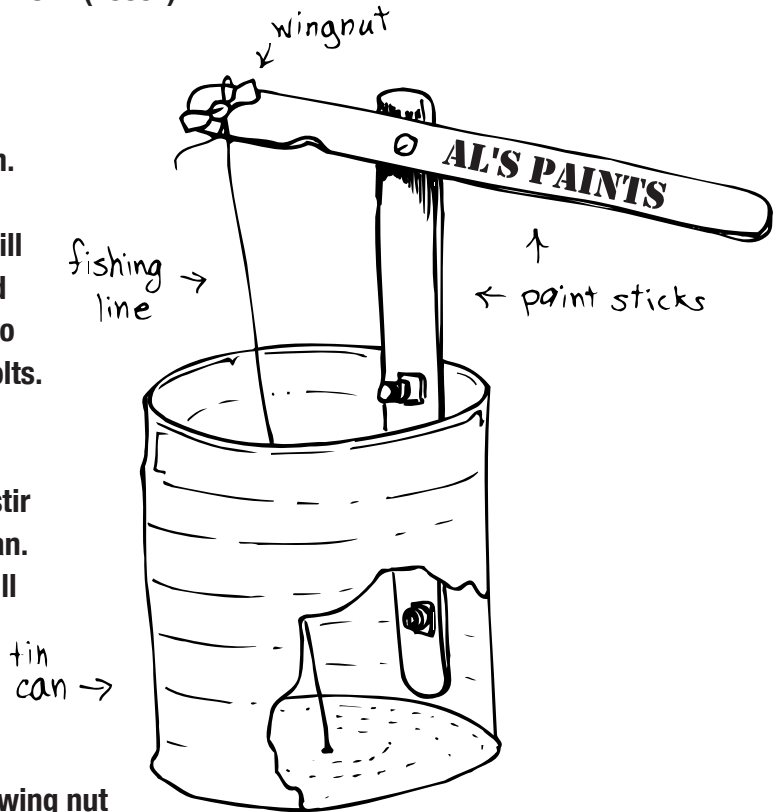

with a wing nut

and a bolt. Make sure the string doesn't touch the side of the can; otherwise you will interfere with the string's vibrations.

By plucking the string and pushing down on the paint-stir-stick-handle you will tighten the string and make the note higher. Twang!

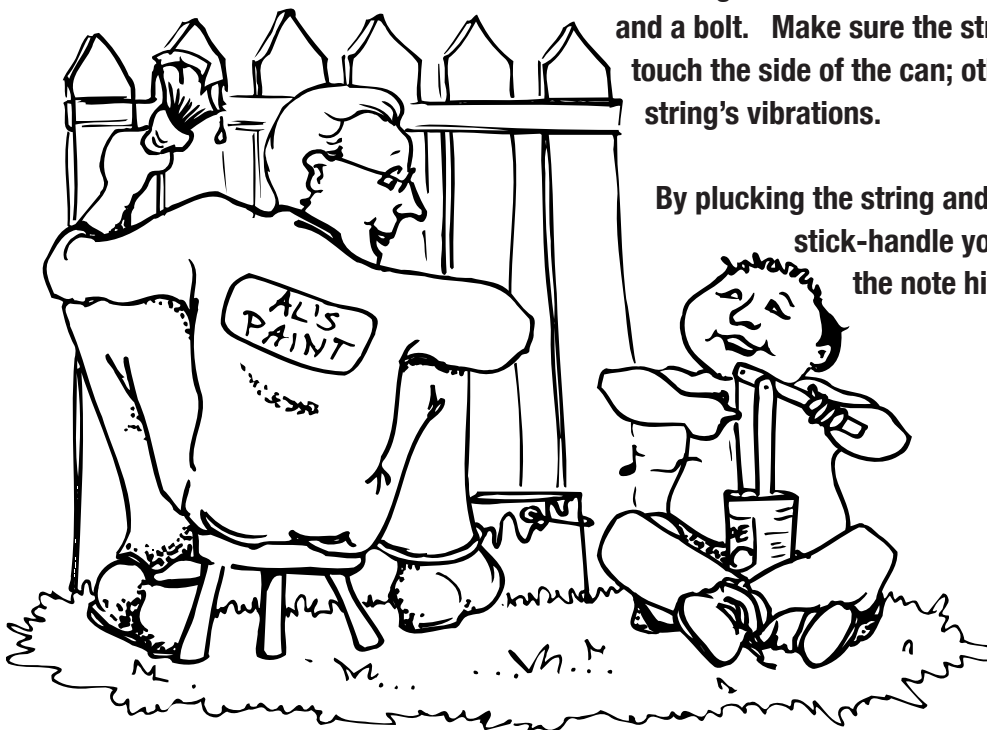

STRINGS (Continued)

Milk Carton Guitar

- 1 250 ml (1 pint) milk carton
- 4 screw eyes
- 1 piece of wood 39 cm x 4 cm x 2 cm
(16" x 1 1/2" x 3/8") approx.
- 4 pieces of fishing line 50 cm (18") long
- 1 stapler (with staples)
- 1 sharp knife (be careful!)
- 1 plastic bread bag closer-thingy (Kwik Lok©) for a pick
- 1 pair of scissors

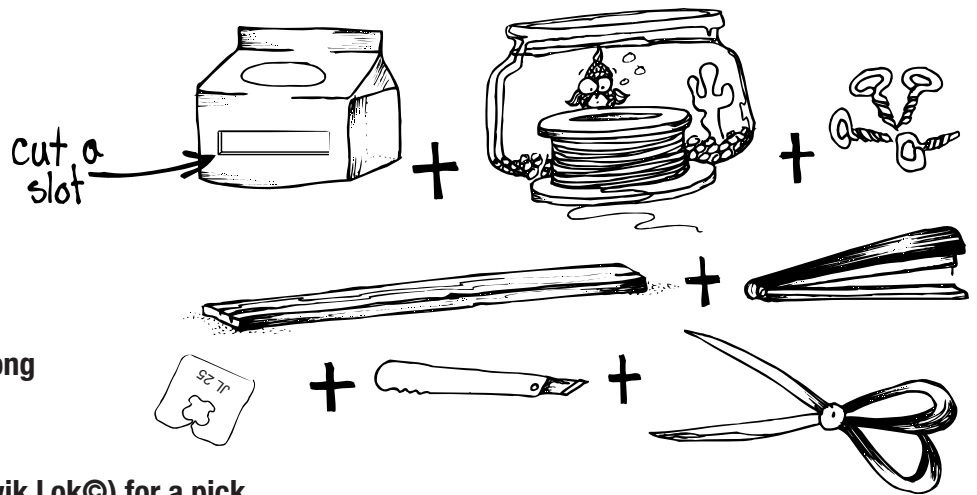

Staple the top of the milk carton closed. It will become the "bridge". Now cut a slot into both sides of the container. Slide the wood into the slot. Staple the fishing lines to the tail end of the board and tie the line to the staple. Partly screw the eyes into the other end of the board and tie the line fairly loosely to them.

The line will tighten as you screw the eyes all the way into the wood. To strum your Milk Carton Guitar, use the bread bag clip as a pick. "Hey Jimi Hendrix! Got milk?"



Percussion Instruments

Shake a maraca, bang a drum, hit a xylophone with a mallet, or a pot with a spoon; or even flip a springy door stopper with a finger and you are playing a percussion instrument!



Silent Gong

To make a very private instrument, tie a piece of string to a wire coat hanger and plug your ears with the string, being sure to keep the string free to vibrate; don't let it touch your clothing. Make the coat hanger bump into a wall, table or chair. The vibrations from the wire travel up the string to your ears. You hear "GONG!"

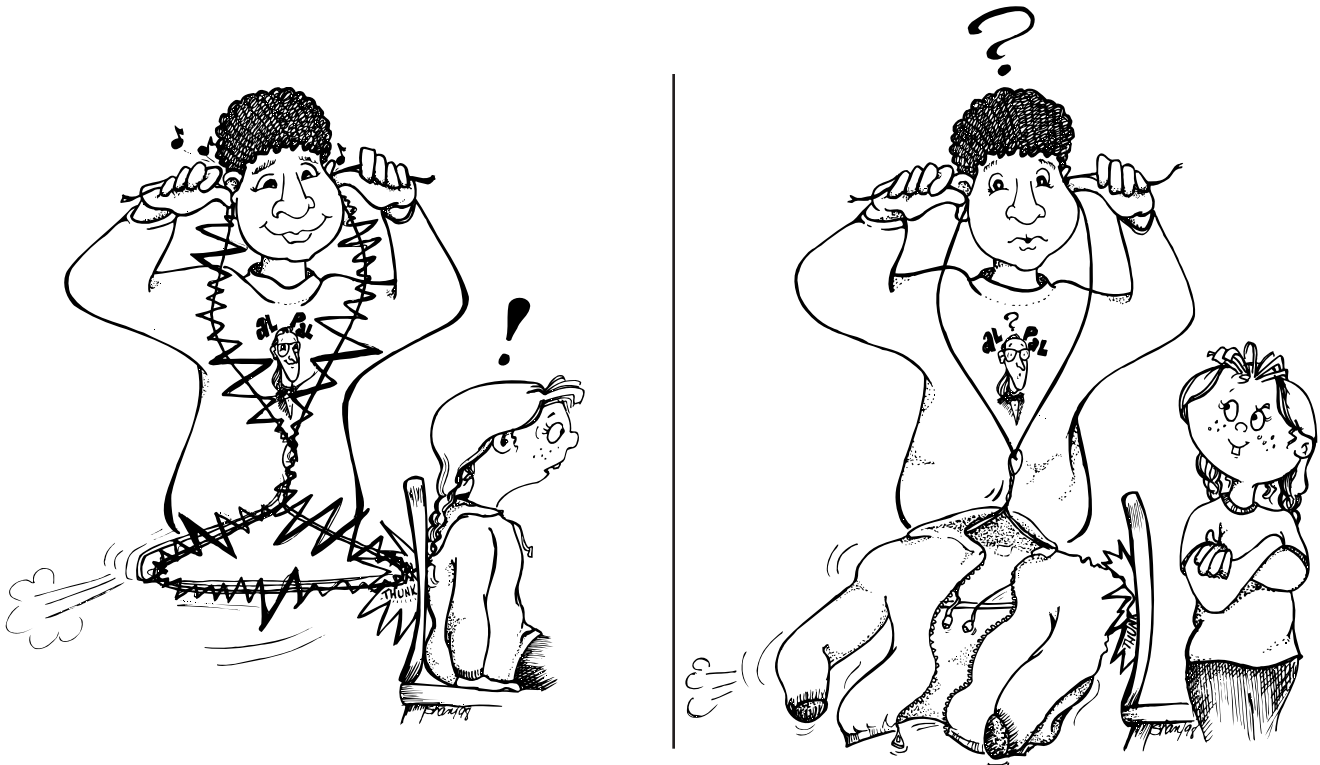

PERCUSSION (Continued)

Kitchen Xylophone

Lay forks, spoons and other kitchen utensils on a thick soft terry towel. Play them by striking them with a wooden spoon.



Spring Boinger

Get someone to help you make this one. Using a hammer and a nail, poke a hole into the bottom of a large tin can. Wind one coil of a large thin wire spring (a slinky works too) into the hole and glue it in place with Shoe-Goo™ or hot glue. Wait until the glue sets, then hold the can and let the bottom tip of the spring bump into a hardwood or tile floor.

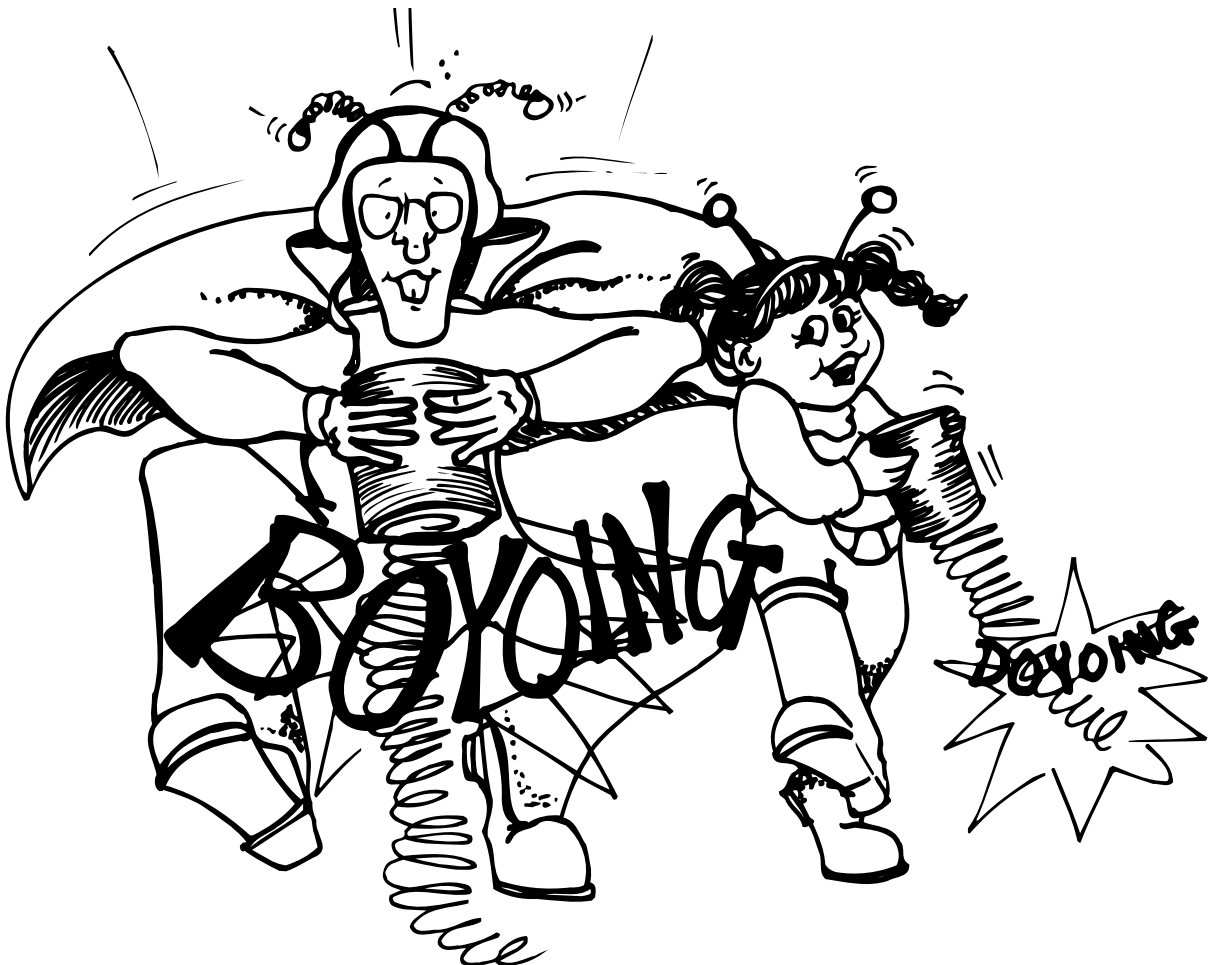
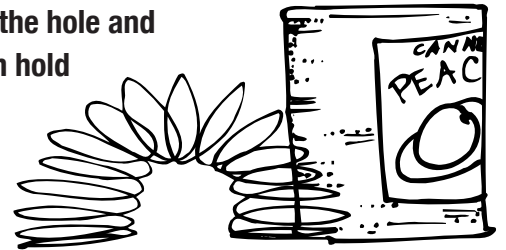

PERCUSSION (Continued)

Ruler Twirler

Drill a hole in one end of a 30 cm or 12" ruler or an equivalent size board. Tie a strong two-foot long string through the hole. Hold onto the other end of the string and twirl the ruler around in front of you, being careful not to hit anyone or anything. Once the ruler winds the string tight it will start to spin quickly the other way and you will hear a noise like the sound of a helicopter or a motorcycle.

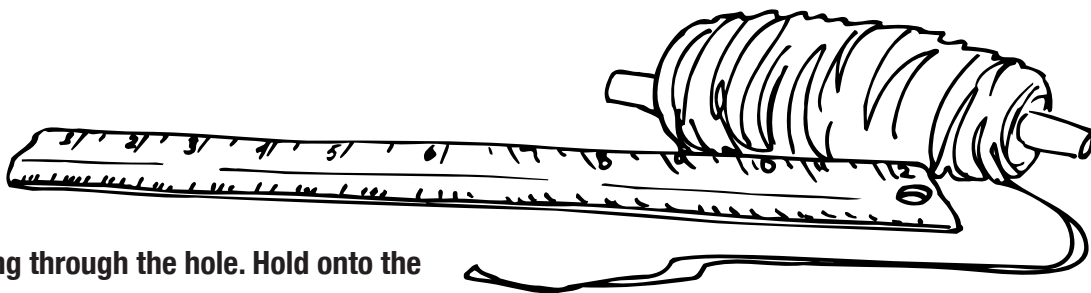

PERCUSSION (Continued)

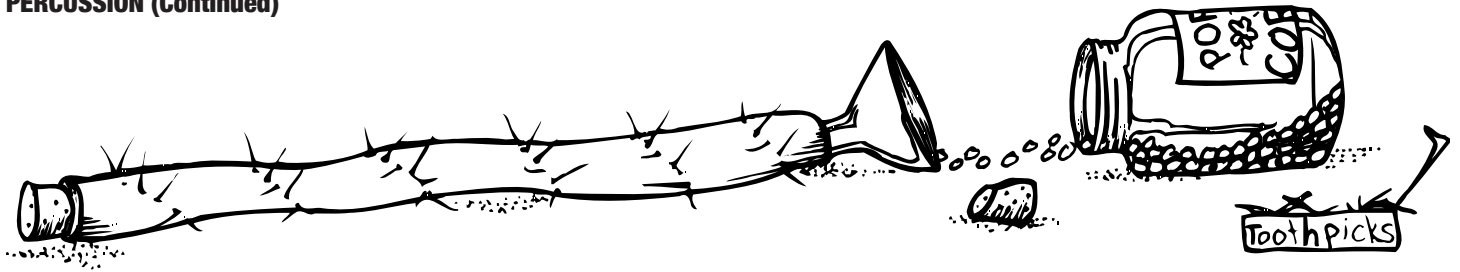

Rain Stick

100 ml (1/2 cup) of unpopped popcorn

30 toothpicks

2 corks or 2 short pieces of 1" doweling

1 meter (3 ft.) or more of 3/4" ethafoam pipe insulation

1 funnel

Pipe insulation is available at any plumbing/hardware store. Push a toothpick through the foam until it pokes out the other side. Do the same with all the rest of the toothpicks so that they are evenly spaced the full length of the tube. Use the cork or doweling to plug one end and put the funnel into the other end of the tube. Pour the popcorn kernels into the tube through the funnel. Take out the funnel and put a cork into the hole. When you tip the tube back and forth the kernels of corn bump into the toothpicks and sound like a rainstorm.

Flower Pot Bells

Different sizes of clay flowerpots make amazing bells. Tie a knot in one end of a rope and slip the other end through the hole in the bottom of a flowerpot. Tie the rope to a rolling coat rack, broomstick, or bar. Use a cork glued to the end of a chopstick as a mallet and play "Where Have All the Flowers Gone." Try holding on to the pot when you strike it and see what happens when there is less vibration.



PERCUSSION (Continued)

Hockey Stick Xylophone

You can make a xylophone out of broken hockey sticks. Make sure all the sticks are the same width or the pitch will be off. Cut the longest ones first so if you make a mistake you can always shorten it and use it for the next note. Lightly glue them to a piece of foam rubber or staple them to a thick piece of cotton rope. It is important that they are able to vibrate freely when you strike them with a stick.

Get someone to help you cut broken hockey sticks to these approximate lengths then trim to tune them to scale:
15, 16, 18, 20, 23.5, 24, 27, 30 cm.

(6, 6 1/4, 7, 8, 9 1/4, 9 1/2, 10 1/2, 11 3/4 inches)

Nail Xylophone

Get someone to help you cut nails to the sizes below using a vice and a hacksaw, leaving one uncut nail as the lowest note. Now lay them on a piece of foam rubber and play them using a nail as a mallet.

Eight - 15 cm (6") nails cut to:

15, 12, 11.5, 10, 9, 8 cm.

(5 3/4, 4 3/4, 4 1/2, 4, 3 1/2, 3 1/8 inches)

Minor Keys:

15, 14, 13.75, 12.75, 12, 11.75, 10.75, 10.25 cm.

(6, 5 1/2, 5 3/8, 5, 4 3/4, 4 5/8, 4 1/4, 4 1/16 inches)

Key Gliss

Using fine fishing line, suspend 'lockless' keys in descending sizes from a stick and create a wonderful sound by running a nail or stick through them.

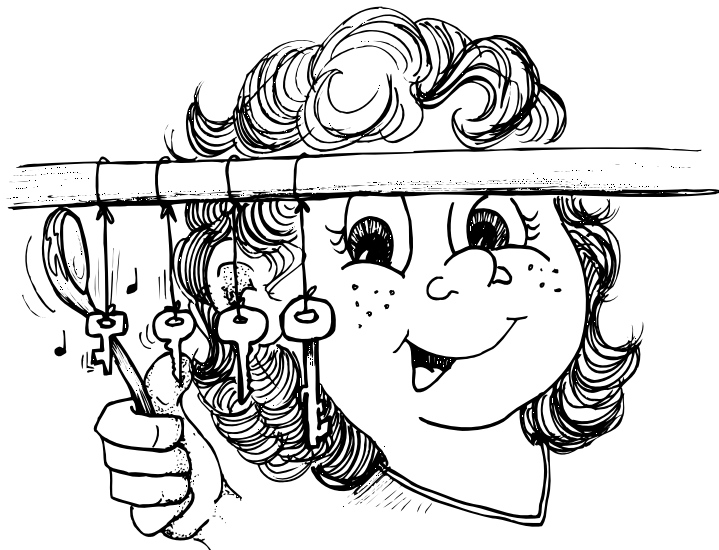
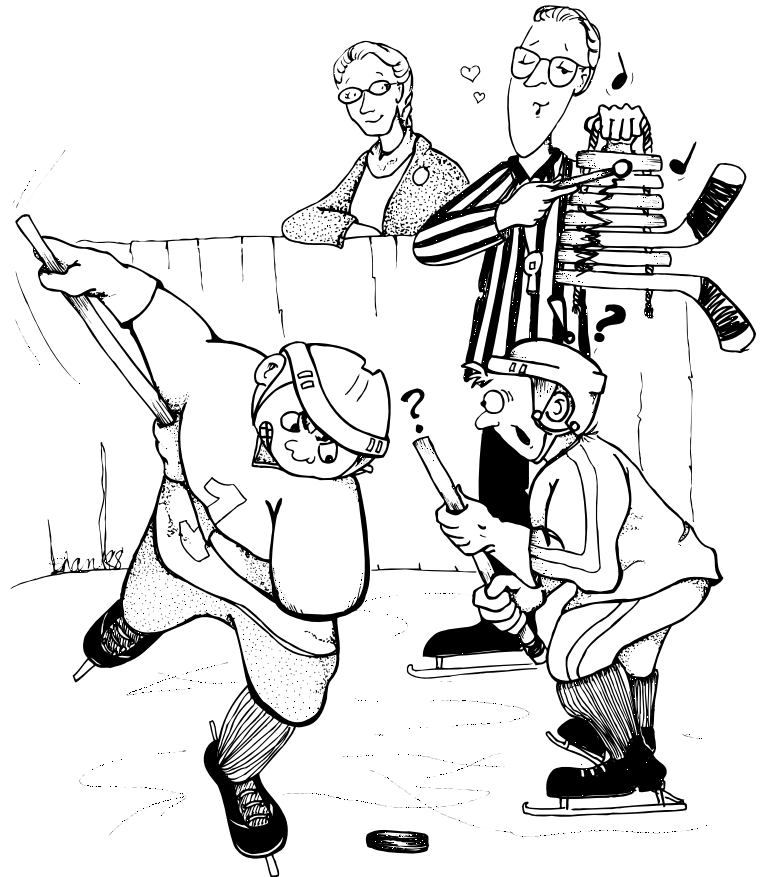

Brass Instruments

Bugle, trumpet, cornet, flugelhorn, French horn, trombone, baritone, euphonium and tuba are all brass instruments.

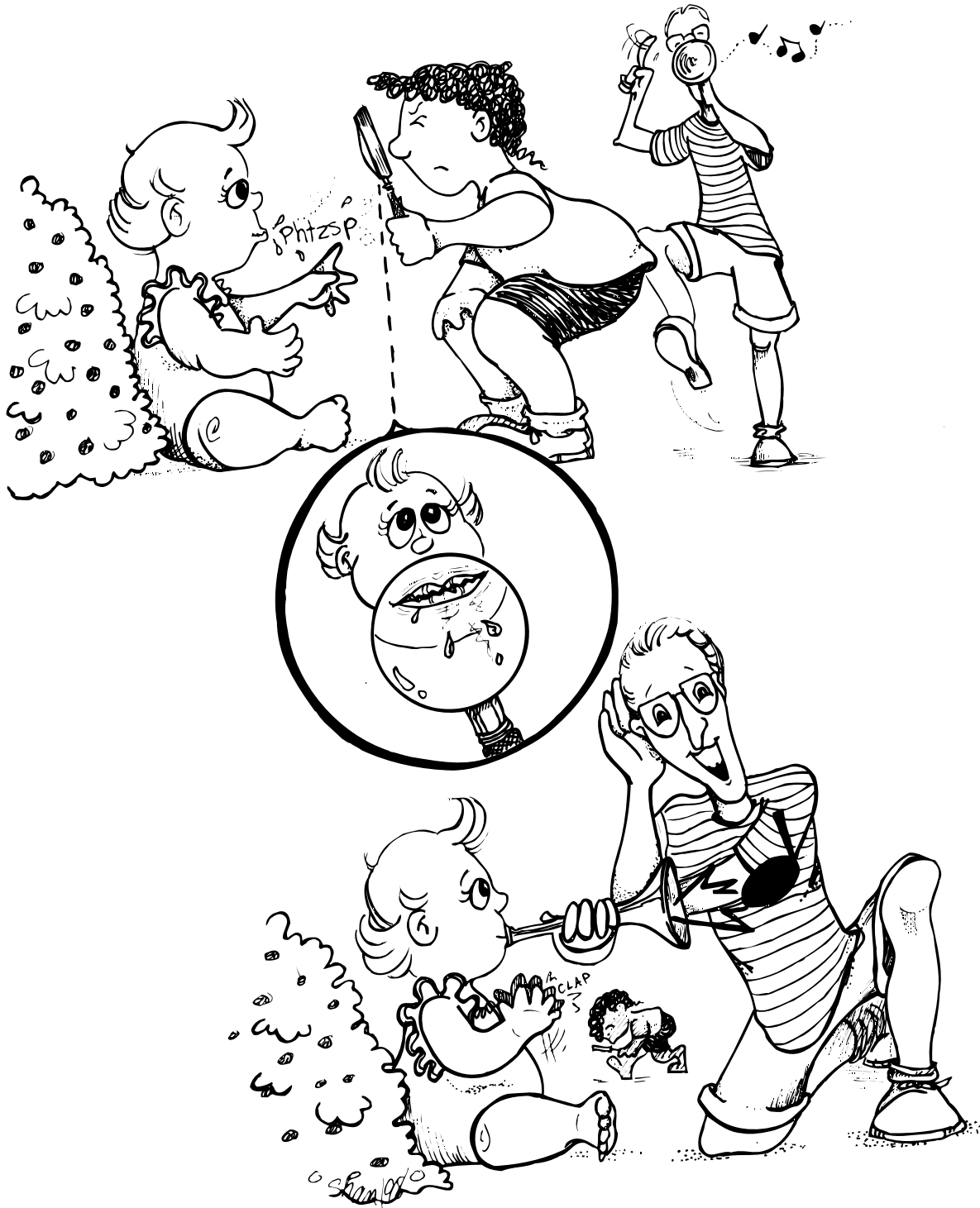

Plastic Pipe Bugle

Make a raspberry or buzzing sound with your lips and press them against the end of a length of 3/4" diameter plastic pipe. Blow hard and vary the tightness of your lips to change the note. Make sure the pipe is clean and has no sharp edges. A longer pipe makes a lower note.

Woodwinds

The family of wind instruments is a large one composed of whistles (recorder, flute, piccolo and panpipes) and reeds (oboe, bassoon, clarinet and saxophone).



Whistles

Garden Hose Pan Pipe

Blow across the top of a pop bottle and you have a form of flute or a one note panpipe. The bigger the bottle the lower the note will be. Cut an old garden hose into various lengths and put corks or wooden dowels into the bottoms of the pieces. Blow across the tops of them and listen to the different notes. You can tune them by pushing the cork farther in. Attach them together with silicone glue and make a pan pipe.

Bottle Chirper

Find an empty plastic bottle. You can use a film container, a small hotel shampoo bottle or a small plastic pop bottle. The smaller the bottle the higher the pitch of the chirping sound. Get someone to help you cut a slot into the side of the bottle. If it is a film container make the slot 3 cm X 1/2 cm (1" X 3/16"). If you are using a 500 ml (12 oz) bottle of pop make the slot approximately 10cm X 1cm (4" X 3/8"). Make a hole in the lid big enough to stick a piece of string through. Tie the string with the knot on the inside of the container. When you twirl the container around the air rushes into the slot and makes a whistling sound. A small container sounds like a little bird chirping. A large family size pop bottle sounds like a big bullfrog. A container with flat sides, like a film container, works better than one with curved sides.

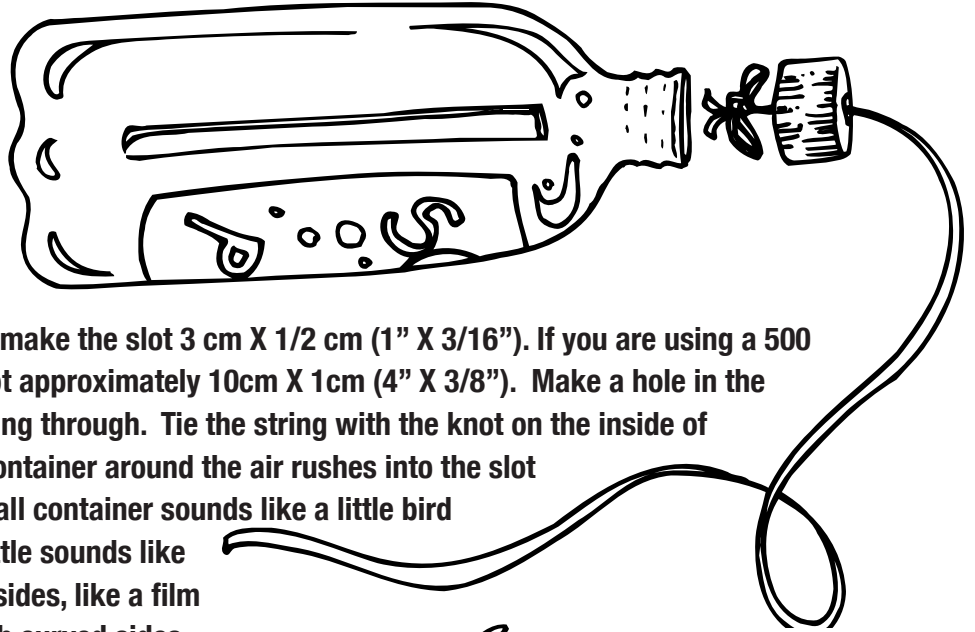

Woodwinds- Reeds

Single reed - One reed vibrates when the instrument is blown into. A saxophone and a clarinet have a single reed.

Double reed - Two reeds are separated by a slight opening. When blown, they vibrate against each other. Oboes, English horns, bassoons, and two blades of grass are all double reed instruments.



Paper Rizzer

Blow between two blades of grass and you have a reed instrument. You can make a simple double reed instrument by blowing between two pieces of paper.

Soda Straw Saxophone

You can make your own double reed instrument out of a wide soda straw. Cut one end of a drinking

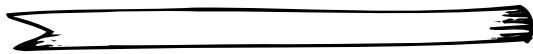

straw to a point. You have created two reeds. If you hold them almost closed with your lips and blow, they will begin to vibrate. Cup your hands over the end of the straw and you change the tone. A shorter straw produces a higher note. Make a slide trombone out of two straws that fit snugly together.



Balloon Horn

- 1 plastic film container
- 1 broken balloon
- 1 7 cm (2 3/4") piece of 5 mm (3/8") vinyl hose
- 1 13 cm (5") piece of 5 mm (3/8") vinyl hose
- A sharp knife (Be careful!)
- An electric drill with a 3/8" bit

To make this instrument you will need an electric drill and a very sharp tool so be sure to get an adult to assist you.

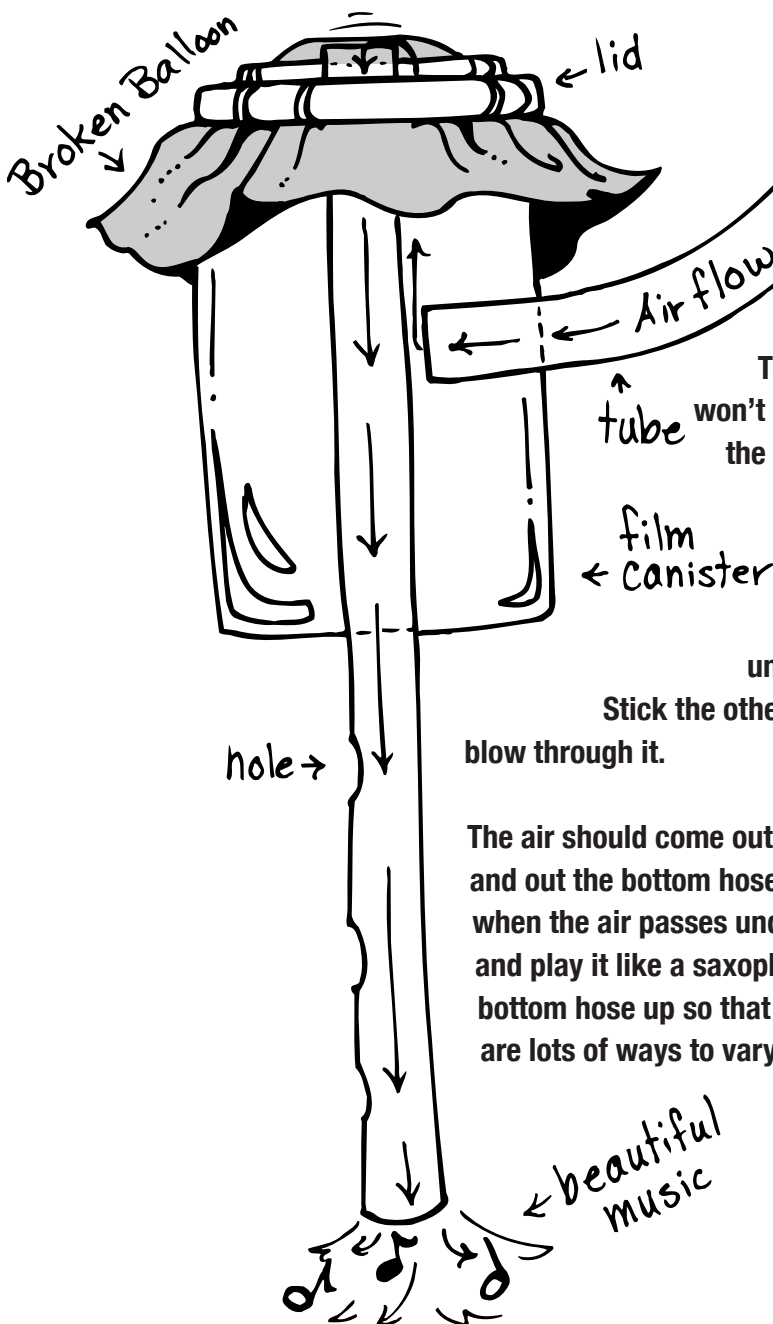
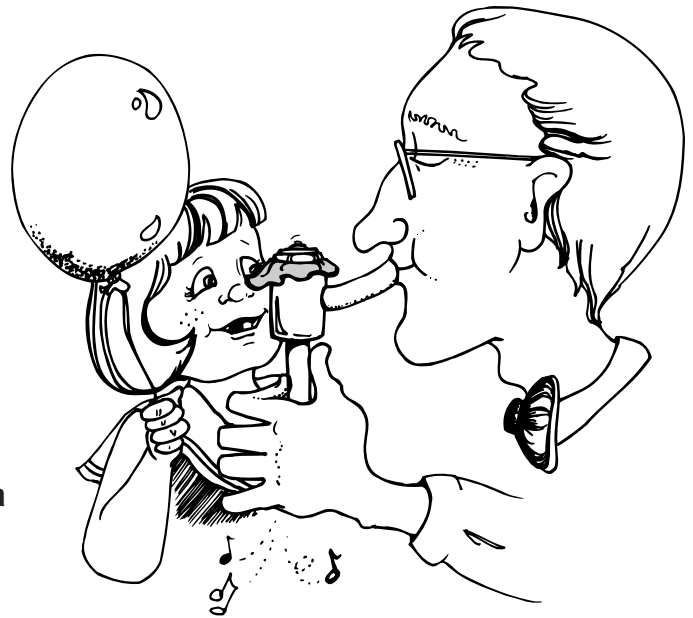

Using a very sharp pointy knife or utility blade, cut a 2cm (3/4") diameter hole in the lid of a plastic film container. Now cut or drill a hole into the side and bottom of the container. The hole should be the same size as the outside diameter of your vinyl hose (3/8" O.D. works well)

The hose should fit tightly into the hole so that air won't leak out around the outside edges of it. Please see the diagram.

Lay a piece of a broken balloon loosely over the top of the container and snap the lid into place. Stick a hose up through the bottom of the container until it touches the balloon and stretches it slightly.

Stick the other piece of hose through the side of the container and blow through it.

The air should come out the side hose, into the container, under the balloon, and out the bottom hose. If the balloon is stretched properly it should buzz when the air passes under it. You can cut or drill holes into the bottom hose and play it like a saxophone. Try blowing harder and softer. Try pushing the bottom hose up so that the balloon is very tight. Now make it loose. There are lots of ways to vary the pitch.

Music Matters



Make time every day to listen to music. From Rossini's *William Tell Overture* to Duke Ellington's *Take The A Train*. From Beethoven's *Fur Elise* to Al Simmons' *I Collect Rocks* (Hey - that's me!). Sound quality is of utmost importance. Find the best sound system available. Even if it is just a large "boom box."

Some music should be listened to with no distractions. If there are funny lyrics, put on some headphones, then sit and listen and laugh along. Some music stirs the soul; other music needs to be danced to. Play a wide variety of music while you are drawing, painting or cleaning up.

Have daily "Jam Sessions," even if it is only hand clapping and foot stomping. Have one group of people keep time by pounding out a loud steady beat while everyone else claps on the off beat and improvises.

If you are playing music with other people think of it as a conversation. Leave gaps in your "dialogue" so that someone else can "say" something - especially if your instrument happens to be the loudest.



ALVIN SIMMONS

I COLLECT ROCKS

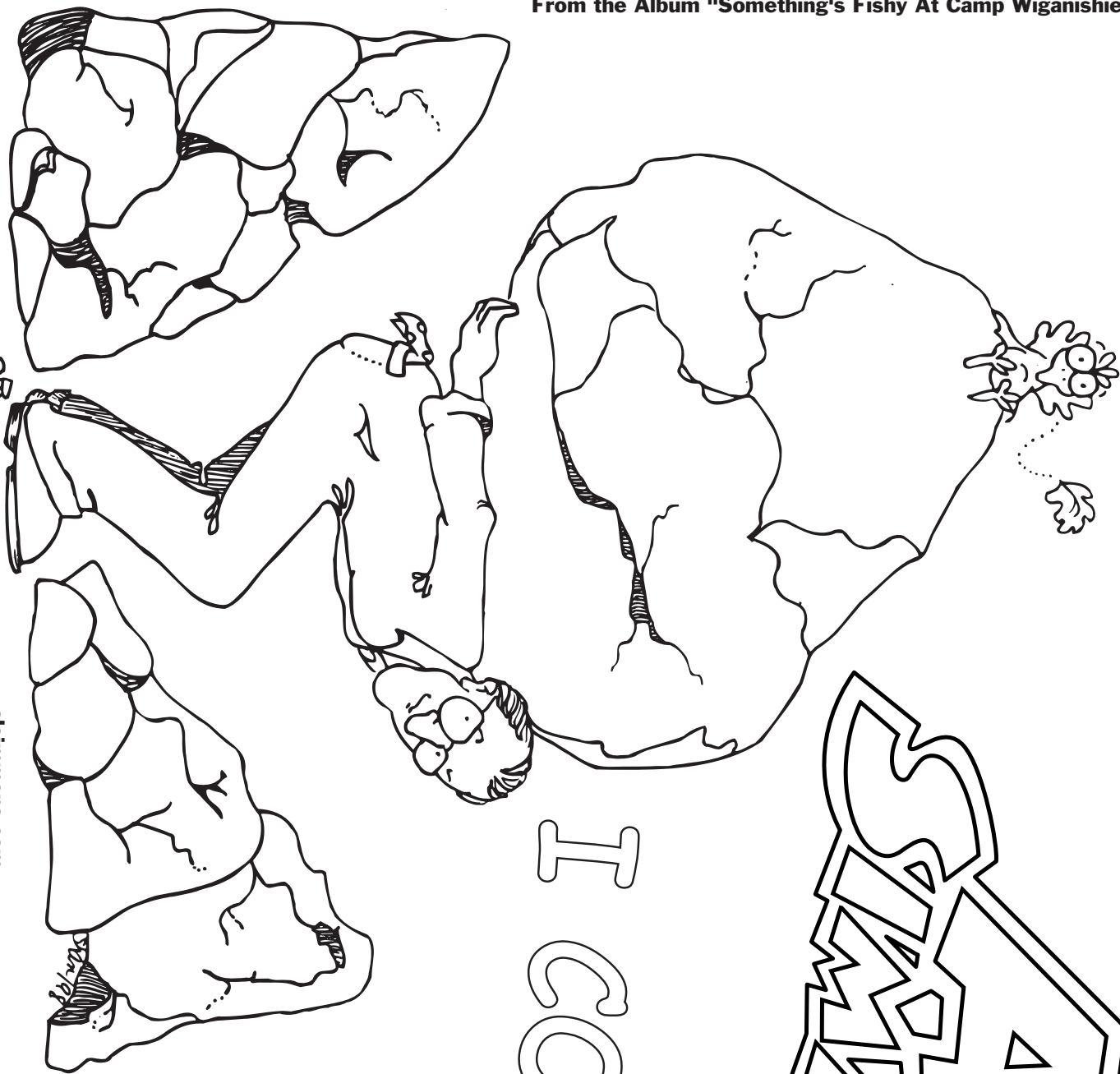

AL SIMMONS

TO ORDER:
 Go to: alsimmons.com/store.htm
 E-mail: al@alsimmons.com
 Fax: 1-204-866-3583

BOOK

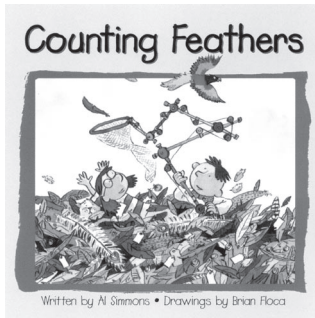

Counting Feathers

Written by Al Simmons • Drawings by Brian Ficca

Based on Al's songs:
 "Counting Feathers & I Collect Rocks"

COLLECT THEM ALL!
 (SUBLIMINAL MESSAGE)

**KIDS AND ADULT
 T-SHIRTS**



"I COLLECT ROCKS" DVD

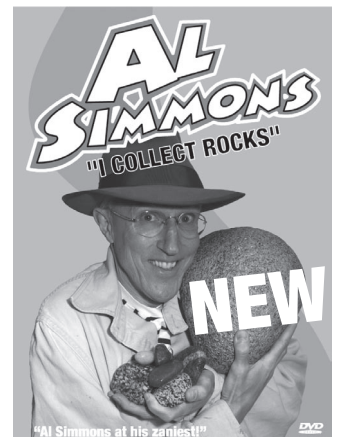

"Al Simmons at his zaniest!"
 A one hour movie featuring 6 music videos:

- It's Raining, It's Pouring
- I Got My Axe
- Counting Feathers
- I Collect Rocks
- What Do You Do With Your Rocks?
- I Got A Horse

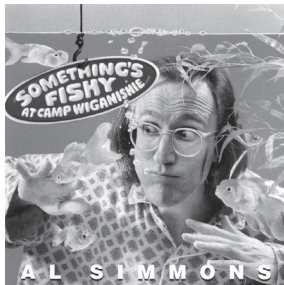

**Something's Fishy
 At Camp Wiganishie**

- Camp Wiganishie
- The Woodpecker Song
- I Want A Pancake
- I Got My Axe
- Bling Blang
- Lego House
- I Gotta Horse
- Something In My Shoe
- Counting Feathers
- I Collect Rocks
- The Stew Song
- It's Raining, It's Pouring
- Singing In The Bathtub
- I Can't Find My Pajamas
- Secret Song
- Little Fishies

— CDs —

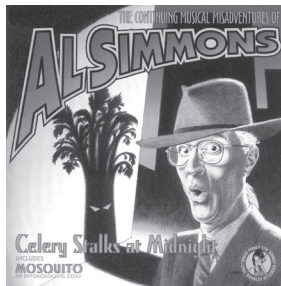

Celery Stalks At Midnight

- Discover Me
- Celery Stalks At Midnight
- I.M.4.U
- La Vie En Rose
- My Hat's On The Side Of My Head
- Where Did You Get That Hat?
- Sam You Made The Pants Too Long
- Open The Door, Richard
- Don't Make Me Sing Along
- Baby (Why Are You Crying So?)
- Clothes Encounters
- Mosquito
- Cry Of The Wild Goose

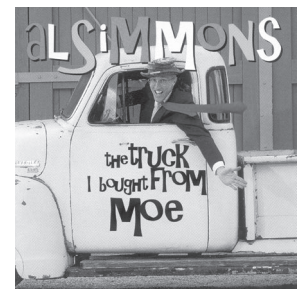

The Truck I Bought From Moe

- The Truck I Bought From Moe
- Gypsy Sock
- Lonely Moose Lament
- Mr. P.G.
- That Johnstown Bounce
- Drip Drip Drip
- I Always Punctuate My P's
- Bud The Spud
- Bag Of Peanuts
- The Dog That Went To Yale
- Round Bales of Hay
- Way Back Home
- The Never Ending Road

www.alsimmons.com/store.htm

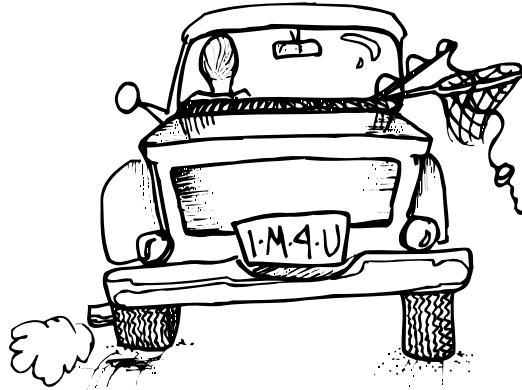

www.alsimmons.com

Copyright ©1998, 2001 Al Simmons
(May be copied for use in schools)
First Published in 1998
Second edition 2001
Third edition 2005
Fourth edition 2007

Written by - Al Simmons
Illustrations - Shannon D. Schultz
Layout Design - Karl Simmons

- Special thanks to -
Anne Thenhaus
Anne Reimer
Dawn Sidley
Lorna Kopelow
Tomás Kubínek
Jonathan Austman